

Grade Two

Classroom

Strategies

Blackline Masters

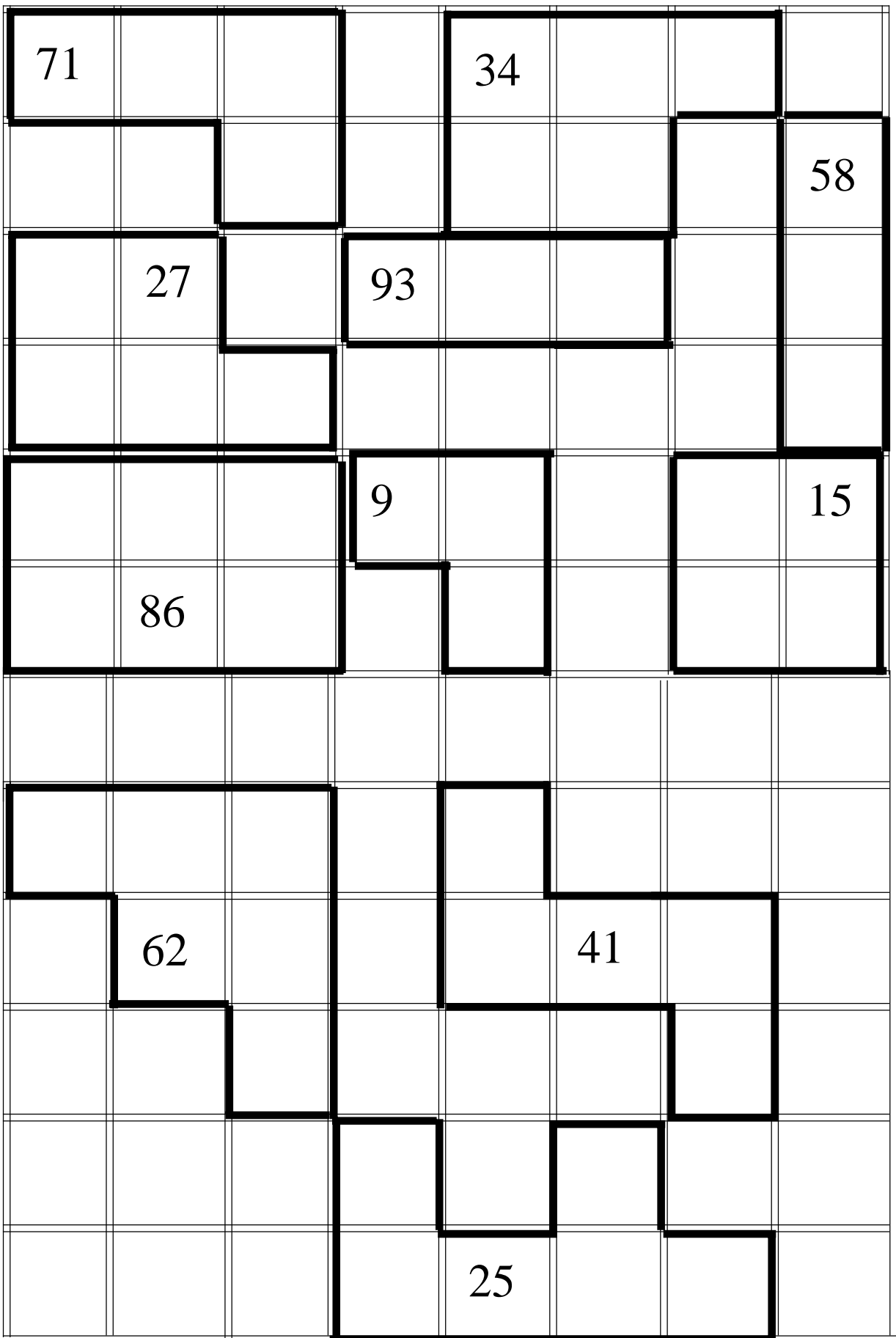

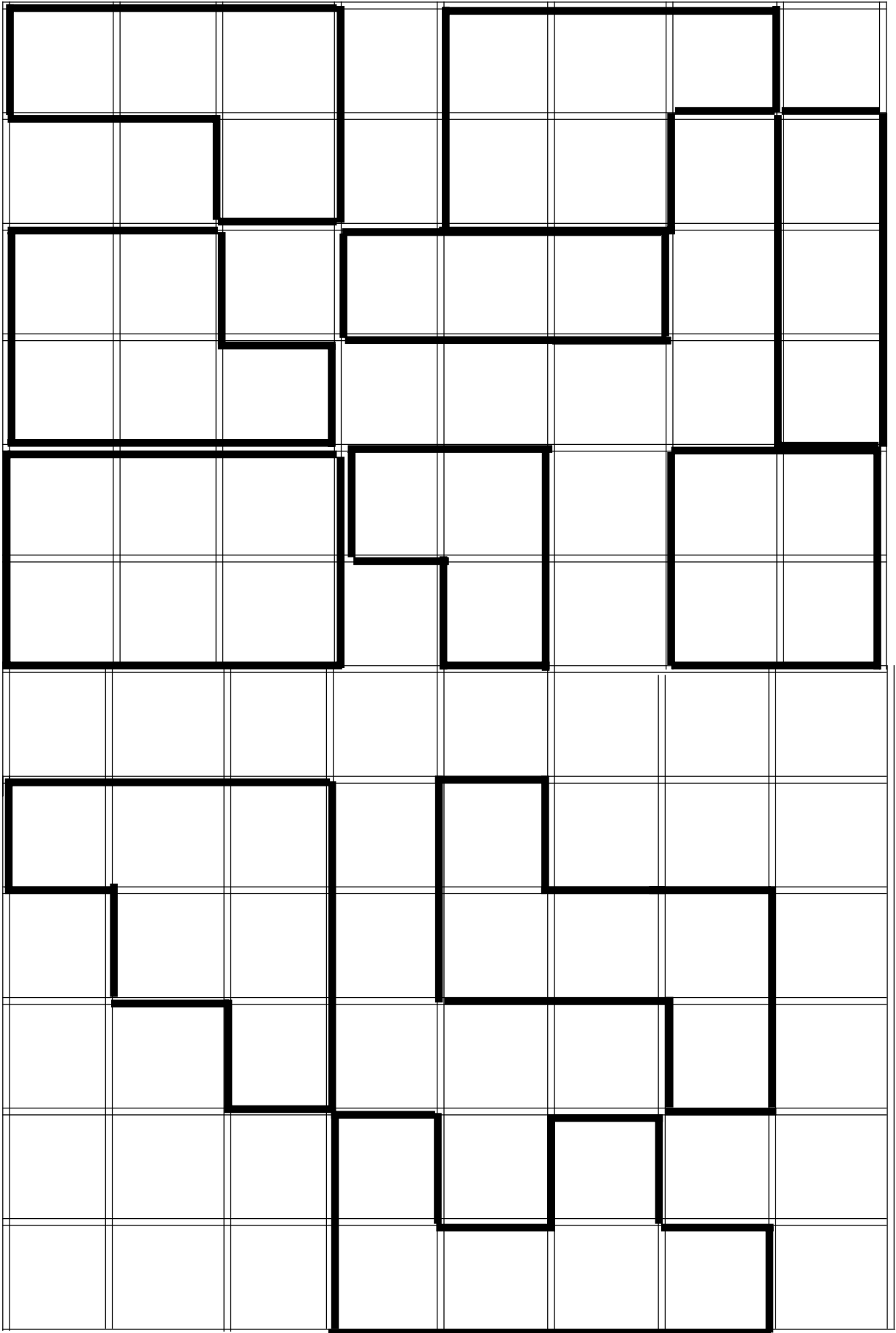

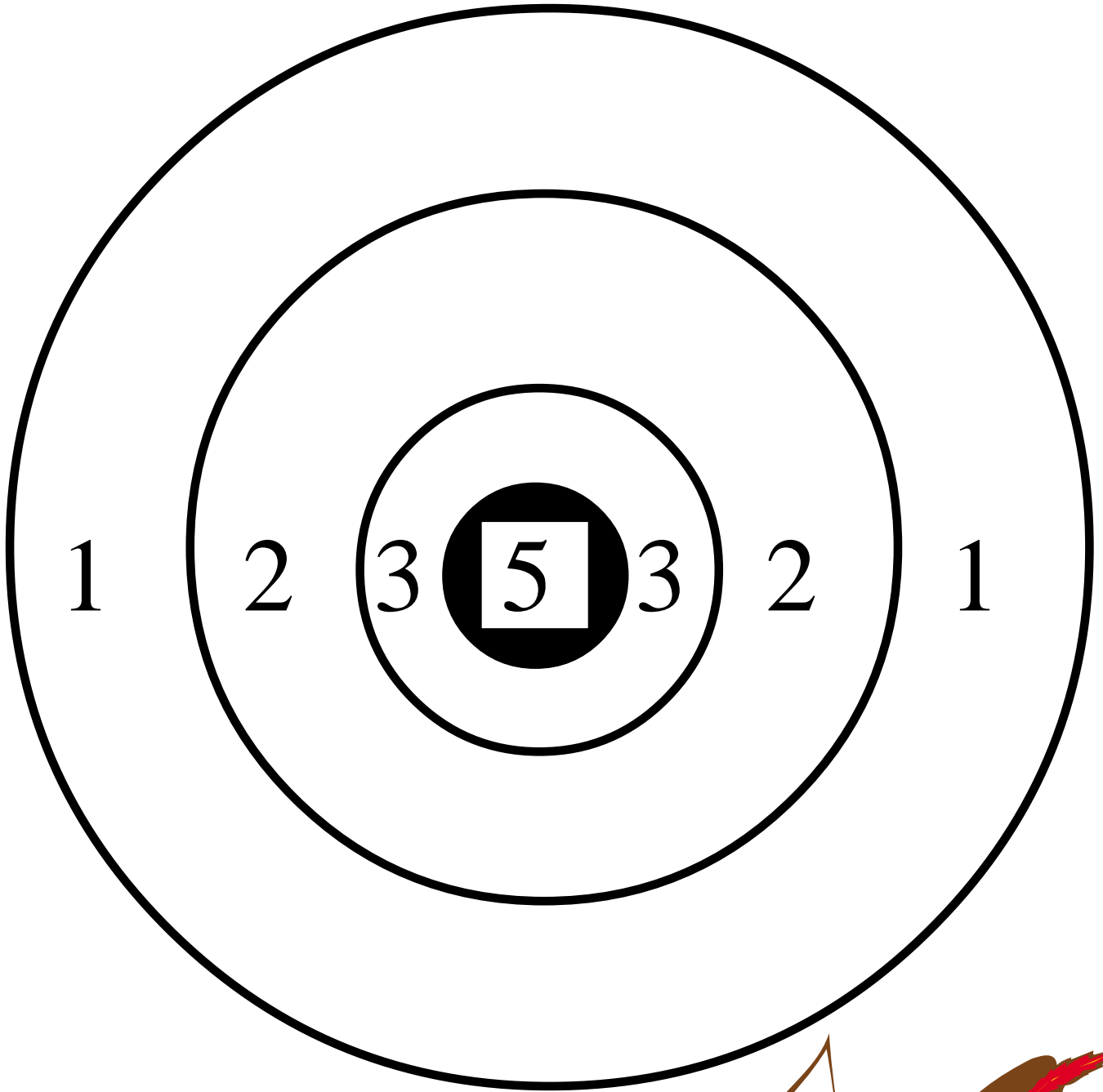

0	1	2	3
4	5	6	7
8	9	9	8
4	5	6	7
0	1	2	3

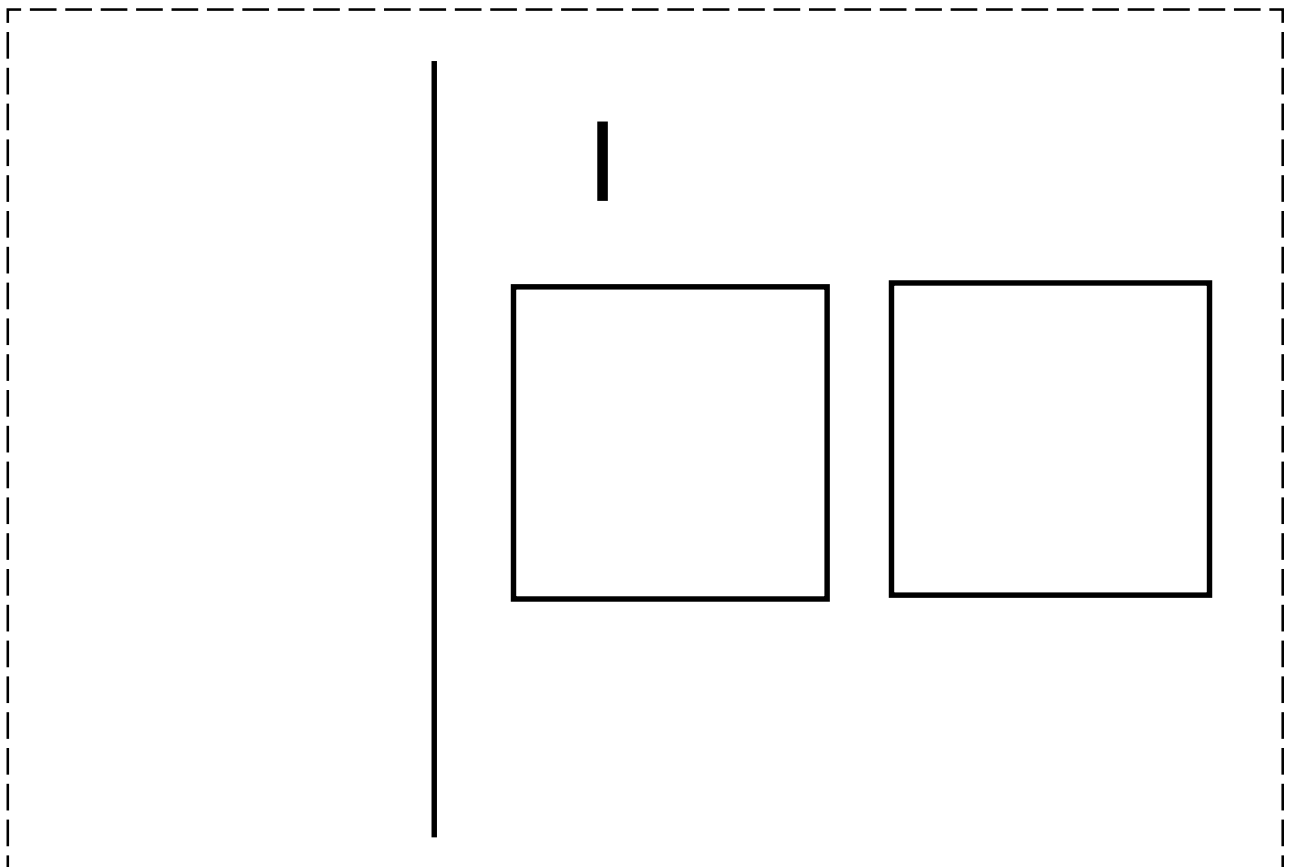
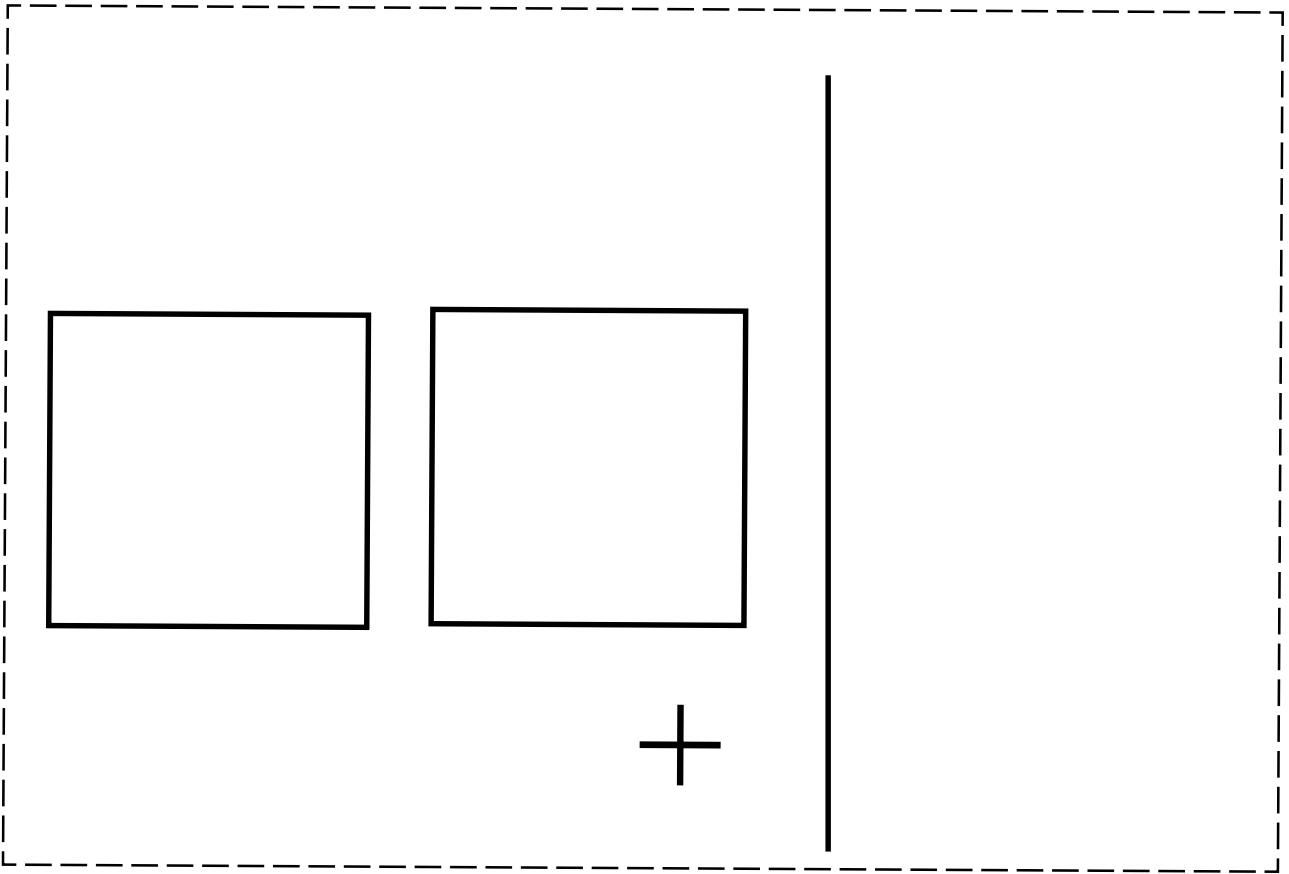

Name: _____

Target Amount:

¢



FOXY BOXES

0

1

2

3

4

5

6

7

8

9



Discard goes here

+

Discard goes here

|



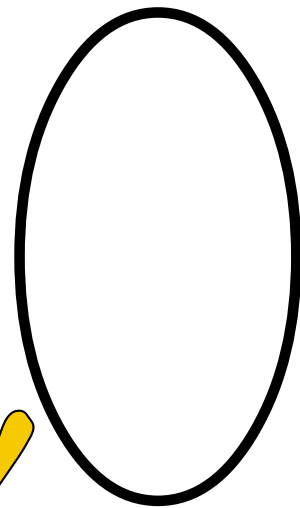
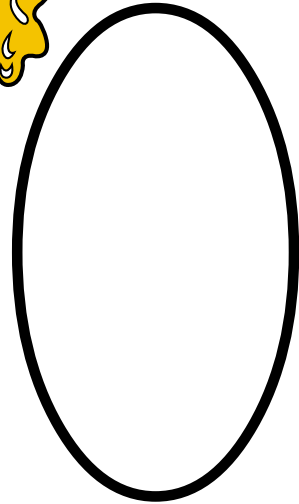
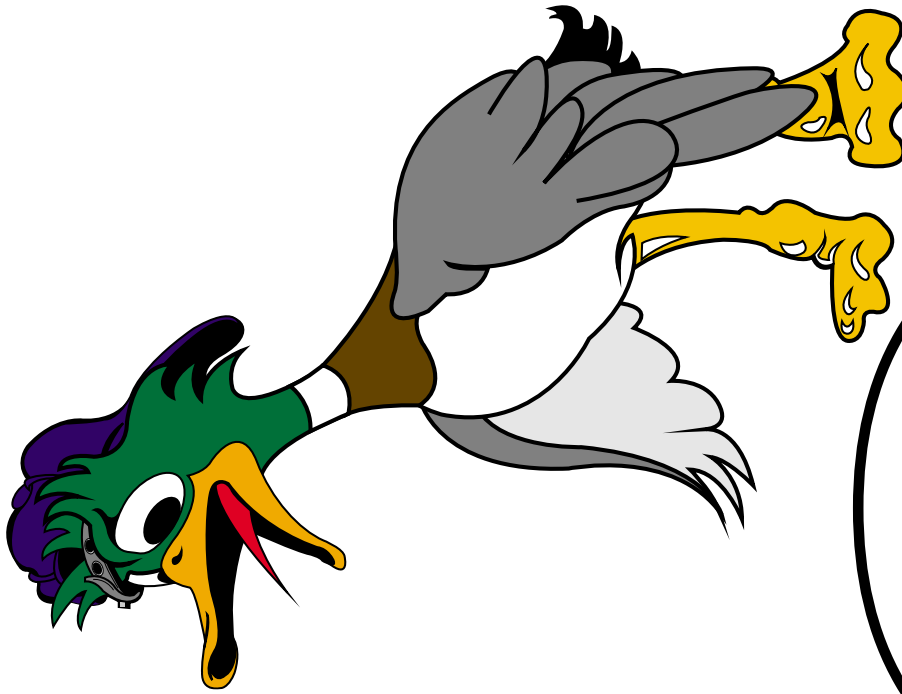

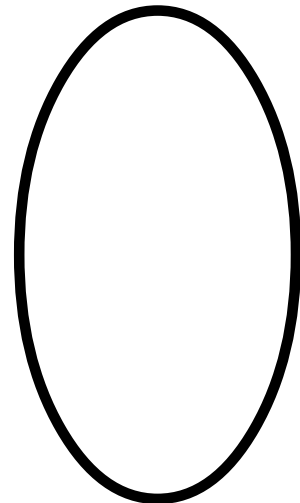
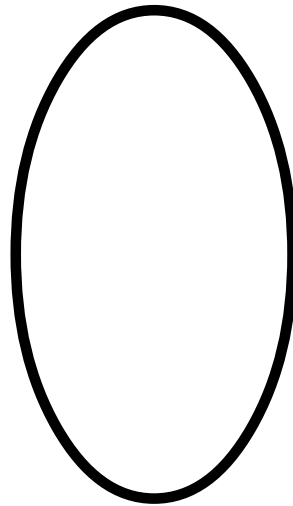
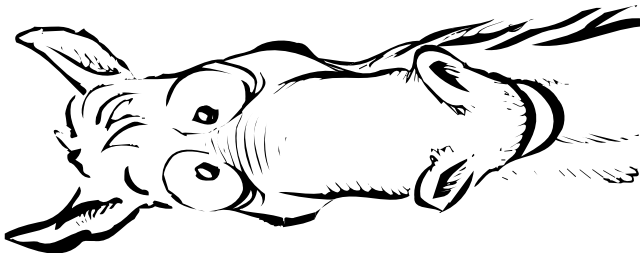
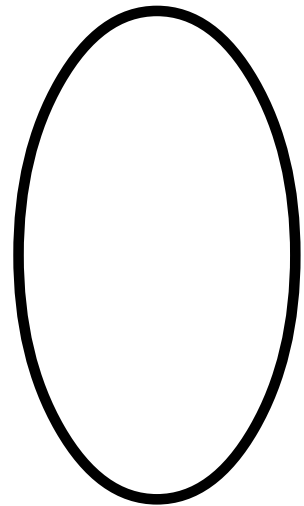

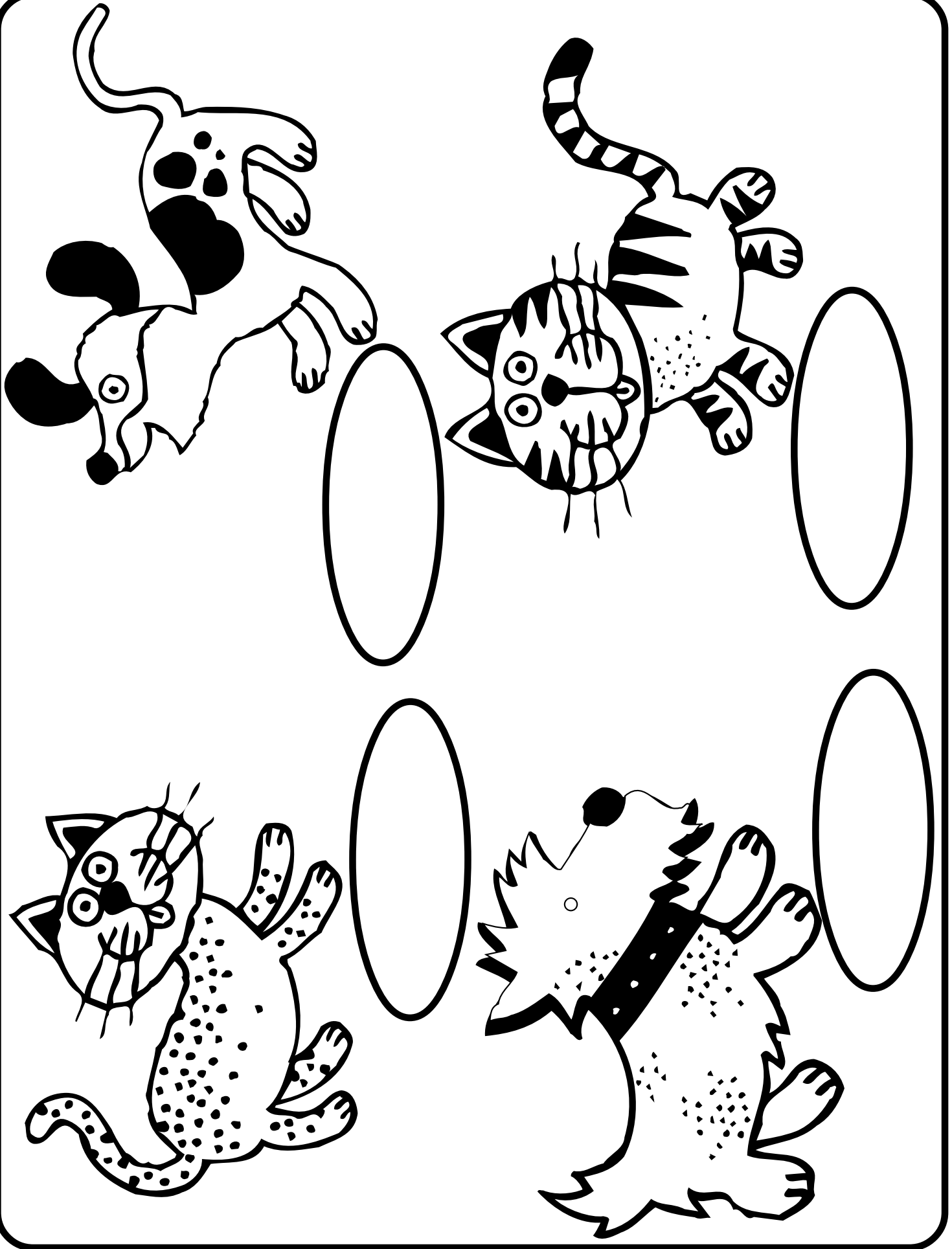

NAME _____

Division Dilemmas

	Number of objects	Number sharing equally	How many did each get?	Leftovers
A				
B				
C				
D				
E				
F				
G				
H				
I				

Directions: Reach into a container and pull out a handful of counters (beans, buttons, cubes, etc.). Complete row A on the chart by dividing into 2 groups. Draw a new handful for row B. Continue in the same manner.

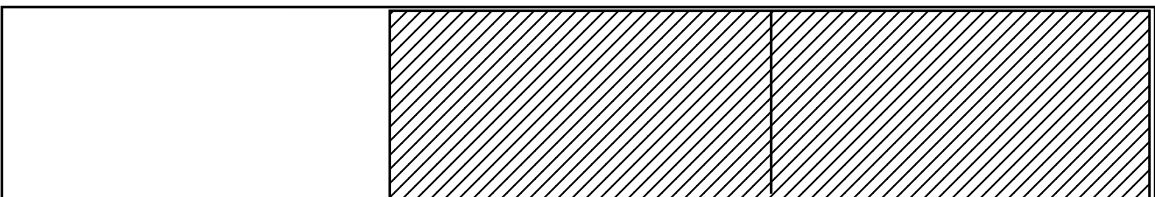
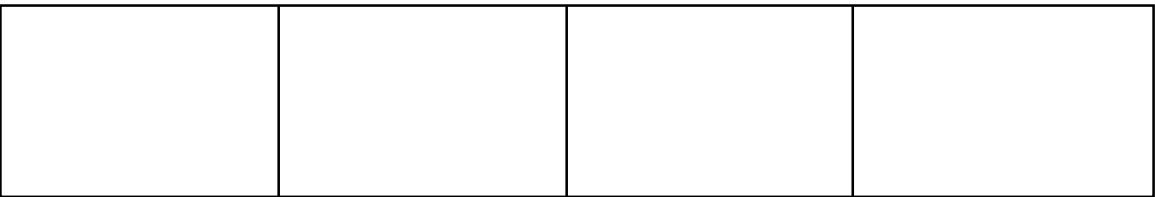
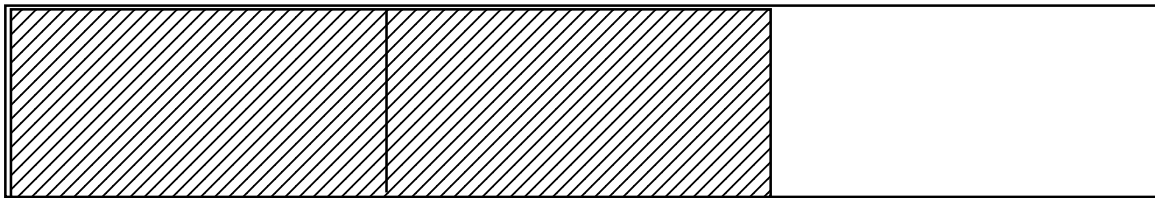
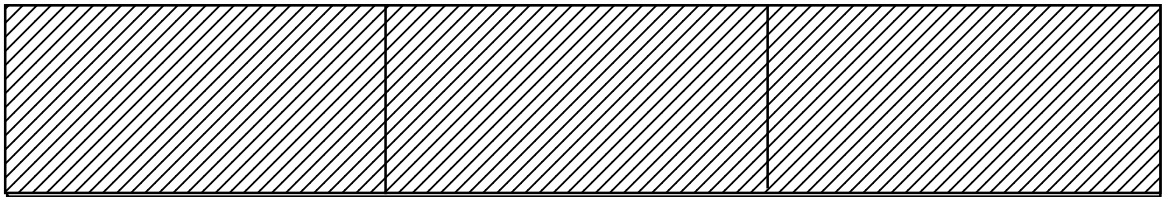

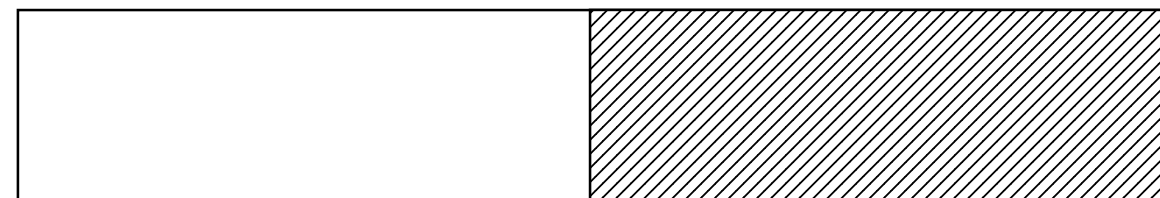
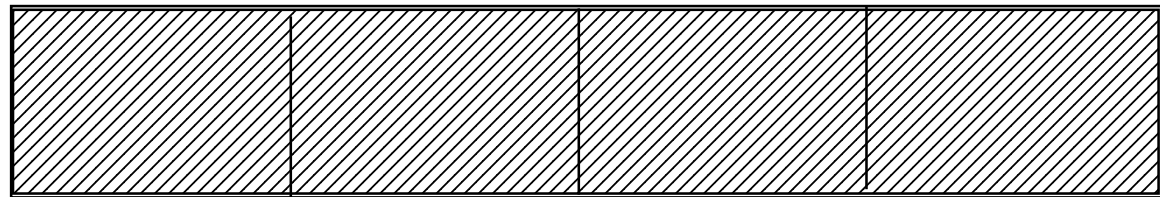
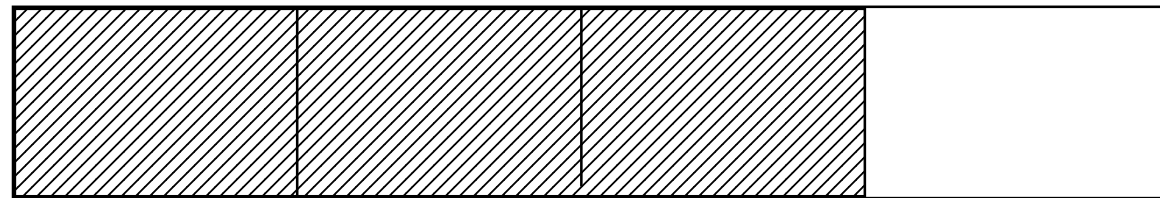
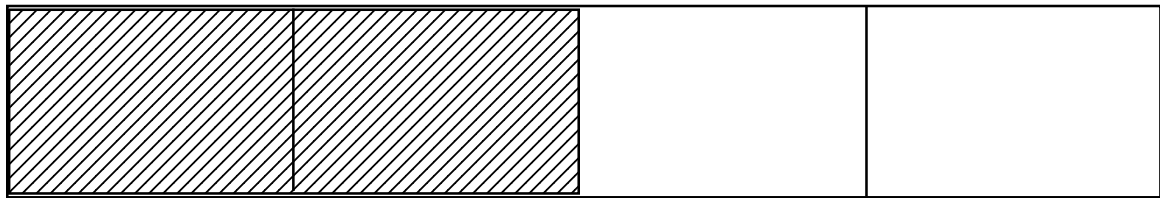
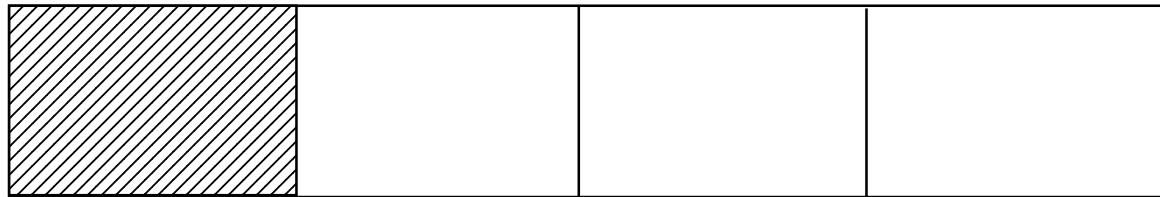
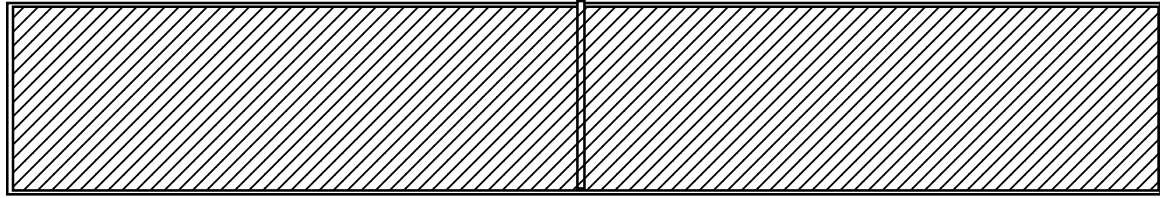
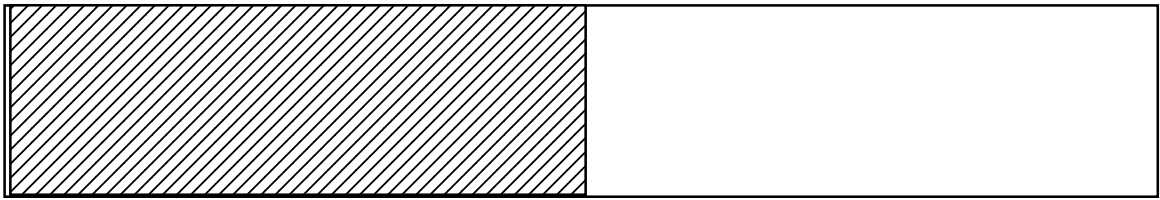

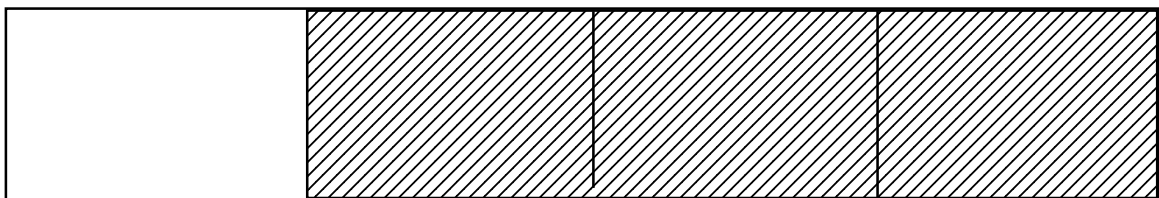
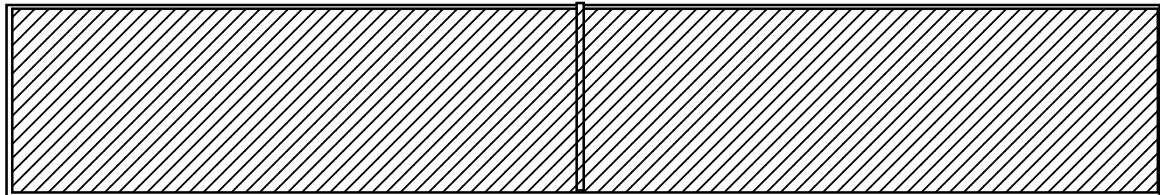
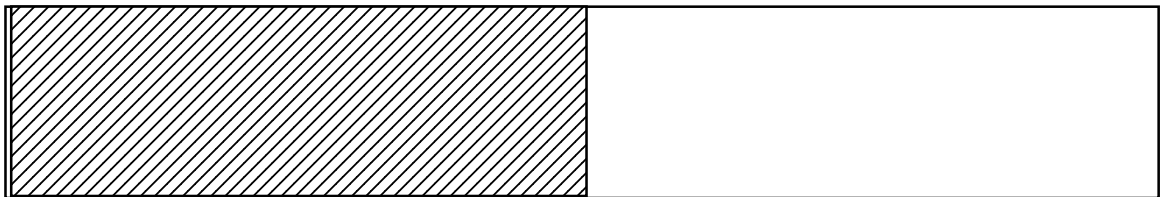
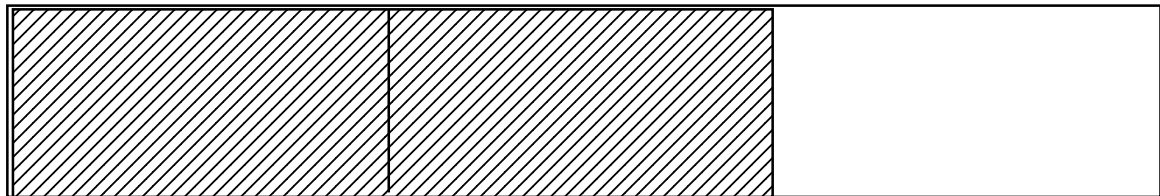
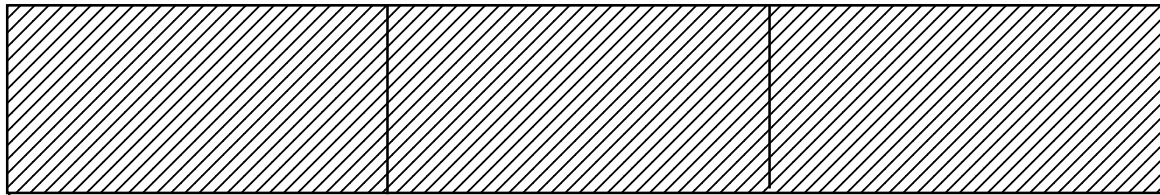

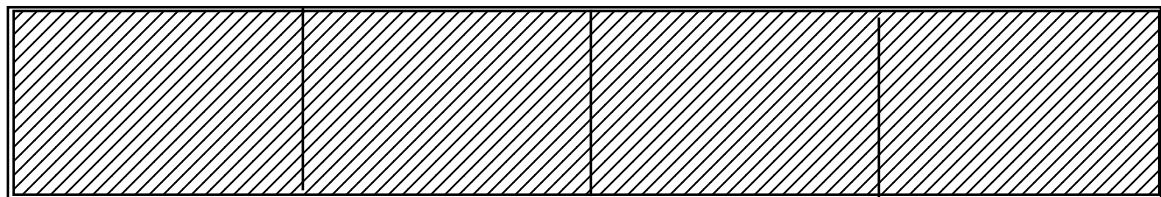
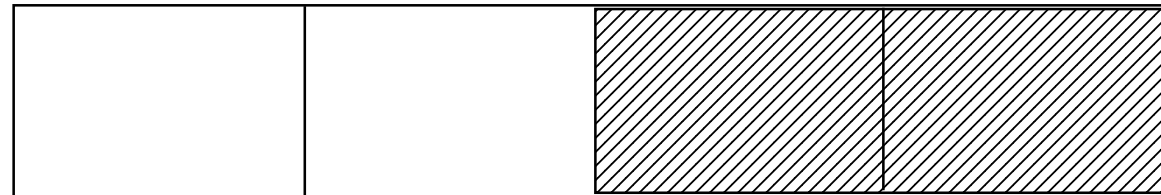
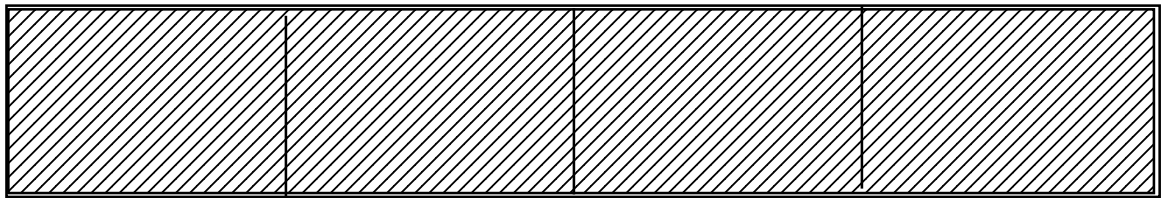
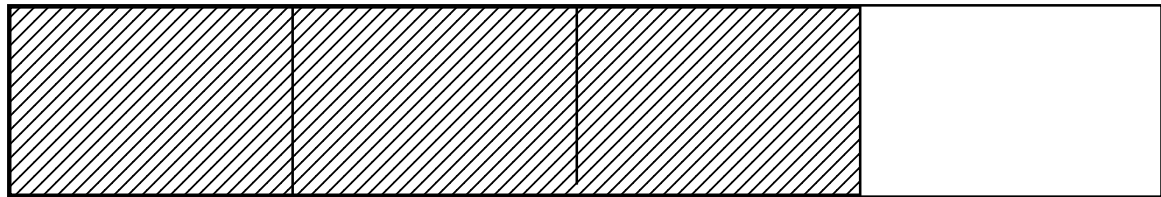
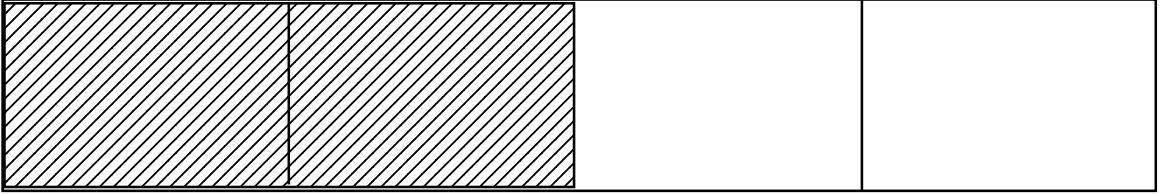
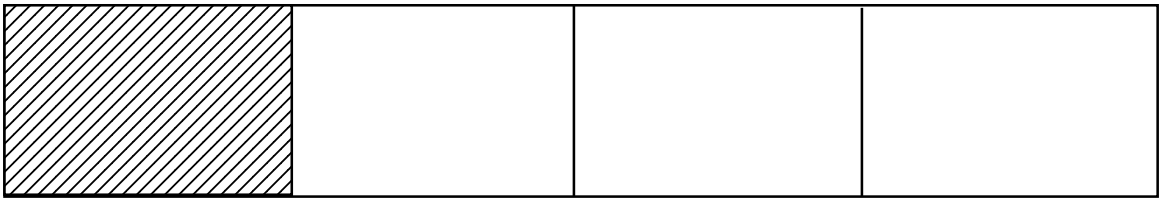

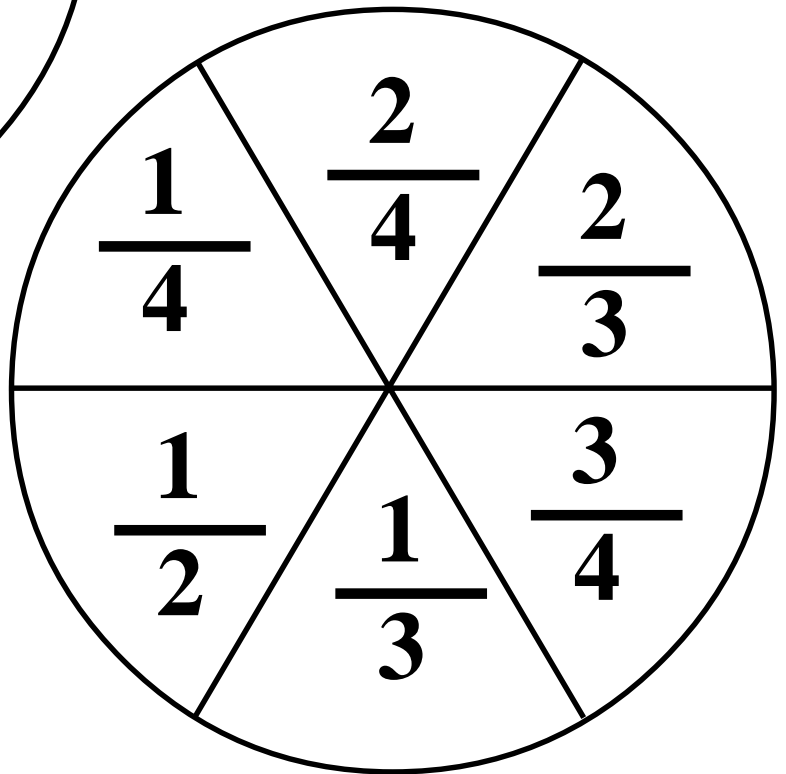
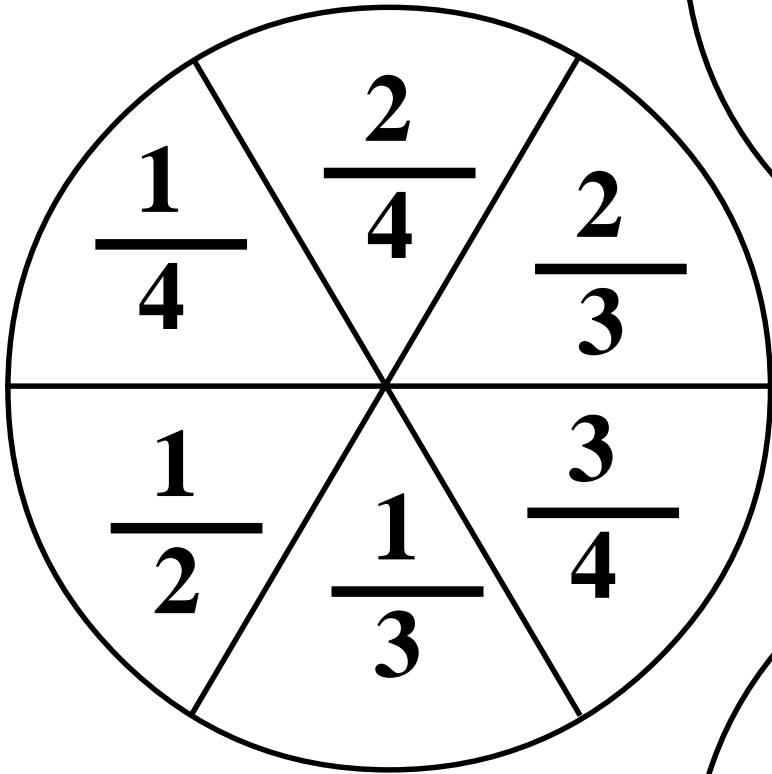
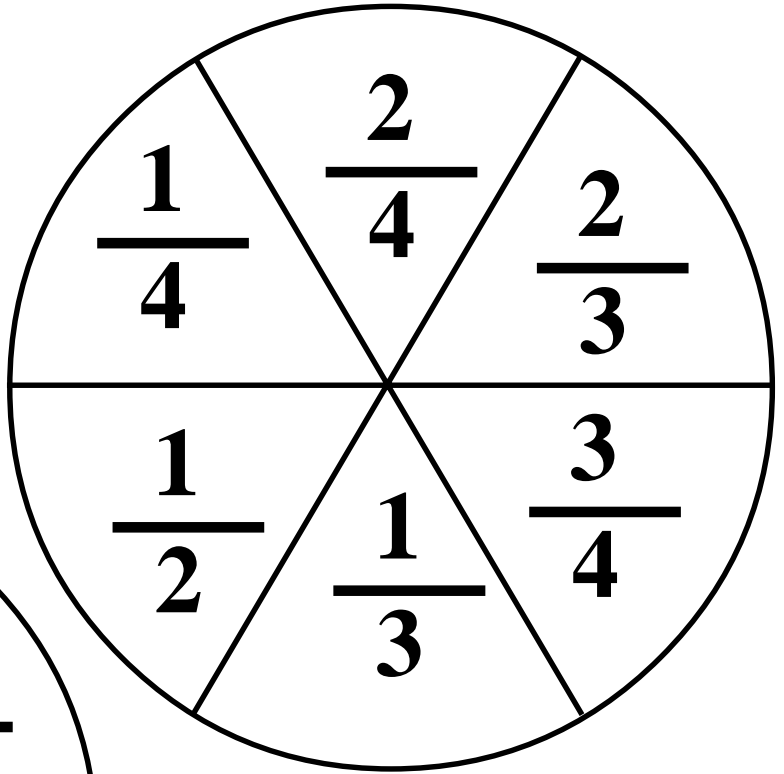

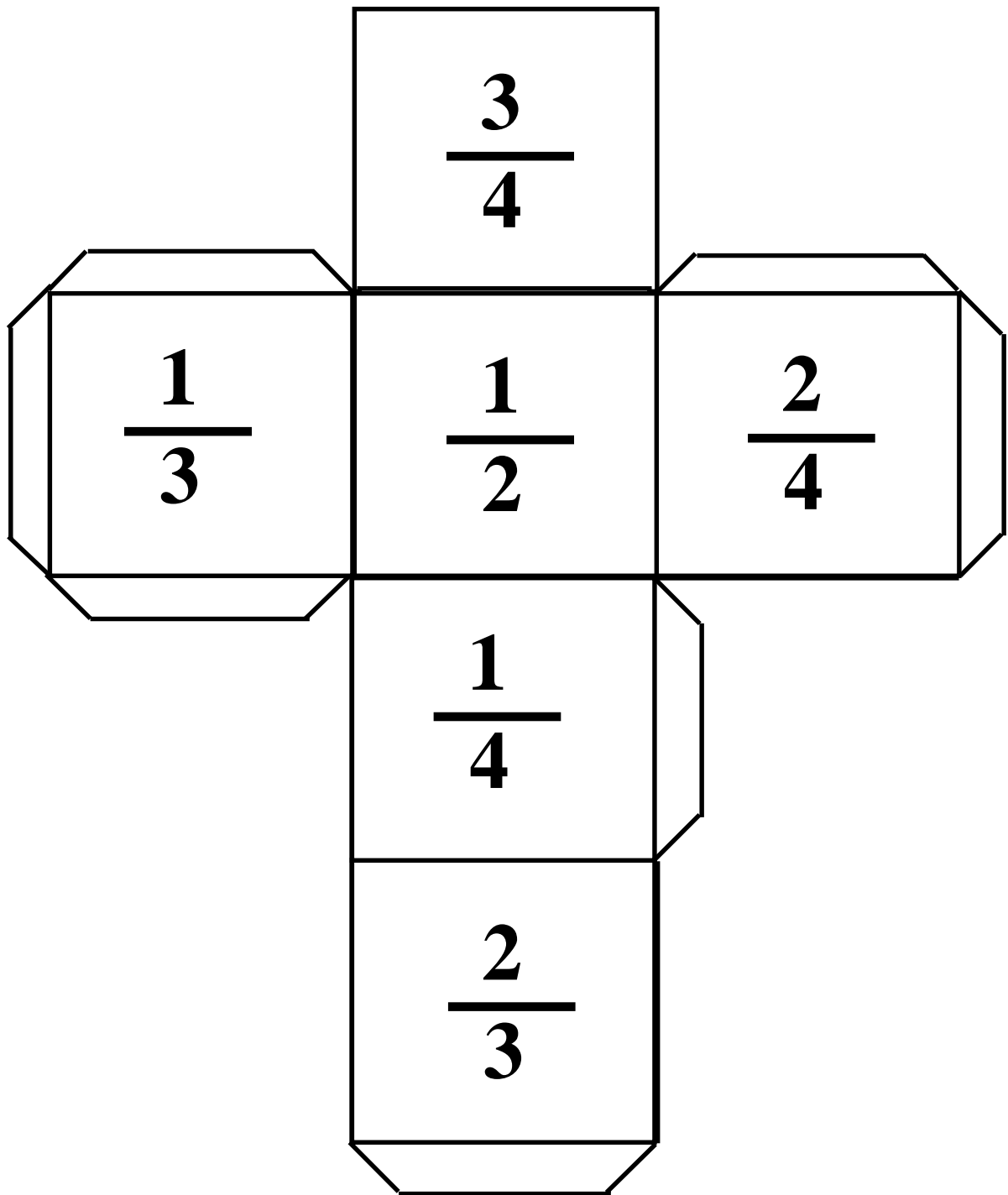

one
whole

$$\frac{1}{2}$$

$$\frac{1}{2}$$

$$\frac{1}{2}$$

$$\frac{1}{2}$$

$$\frac{1}{4}$$

$$\frac{1}{4}$$

$$\frac{1}{3}$$

$$\frac{1}{3}$$

$$\frac{1}{3}$$

$$\frac{1}{3}$$

$$\frac{1}{3}$$

$$\frac{1}{3}$$

$$\frac{1}{4}$$

$$\frac{1}{4}$$

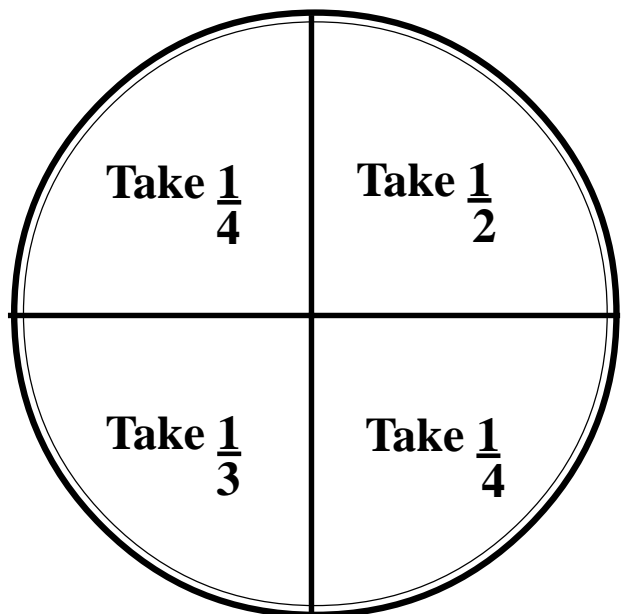

START

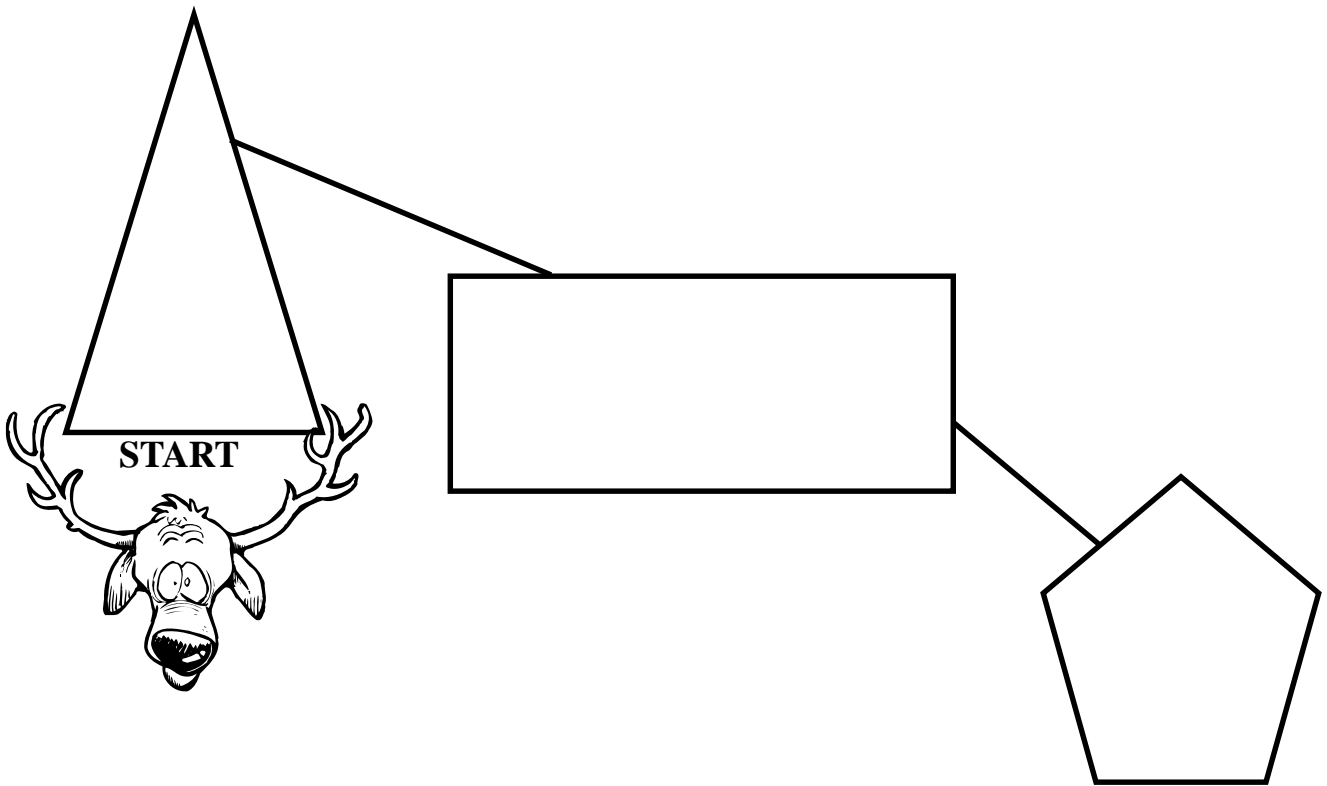
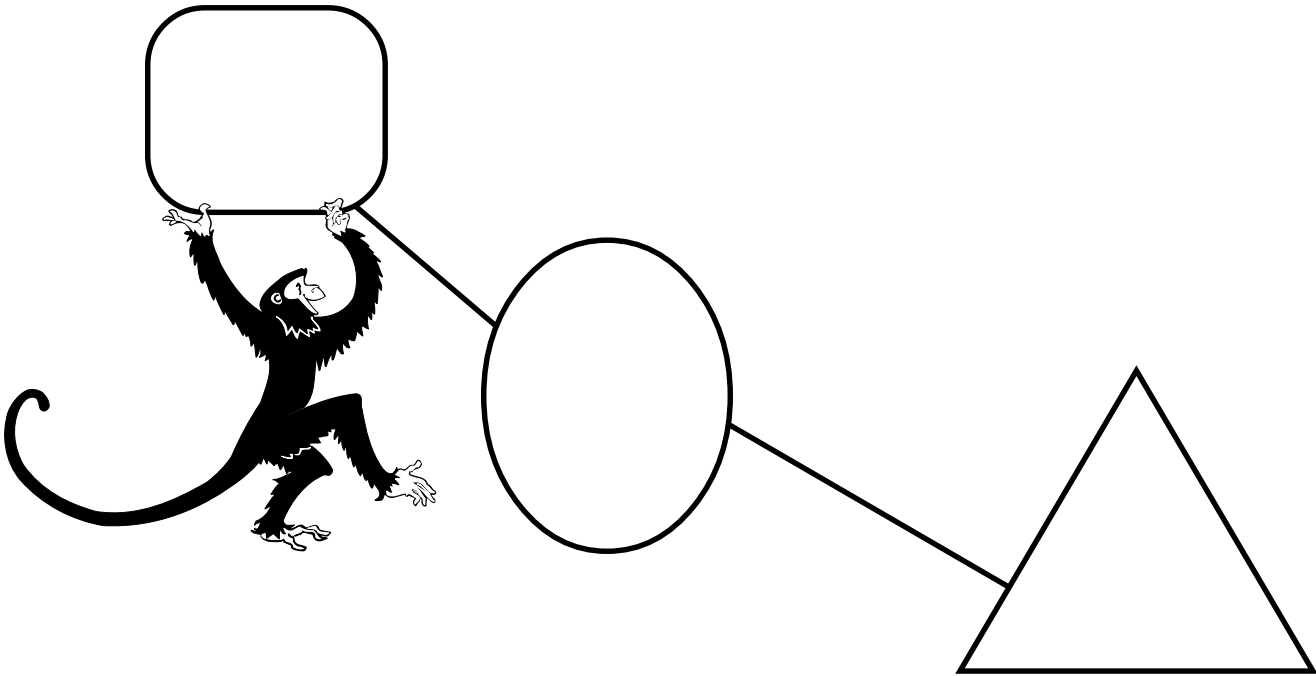

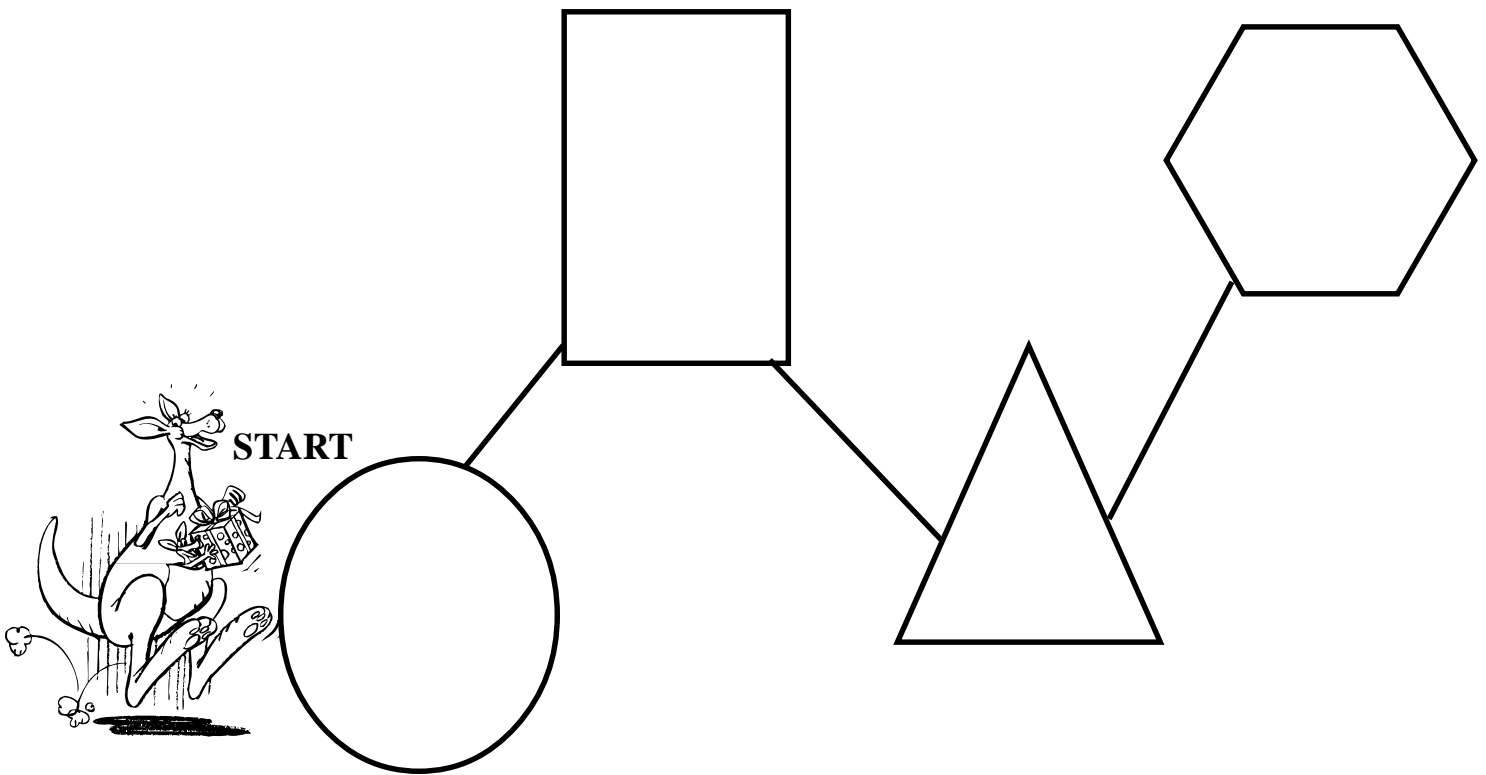
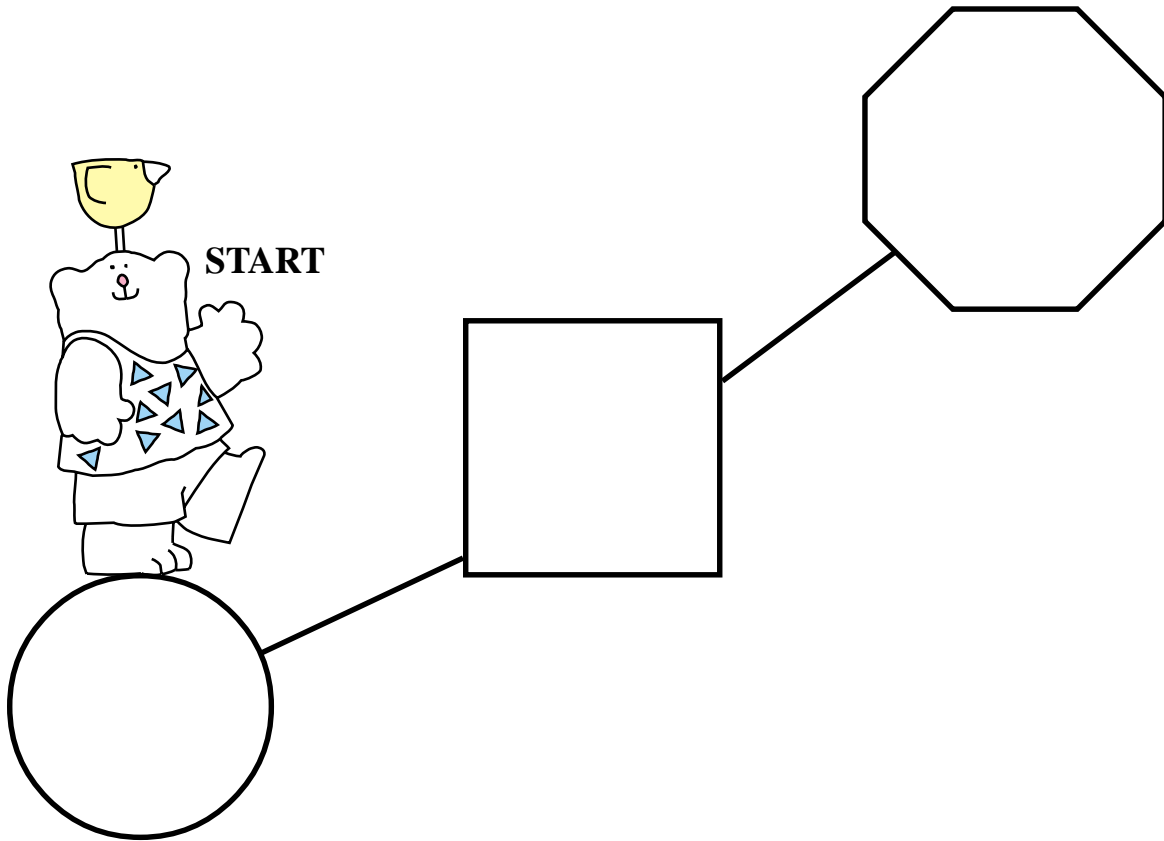

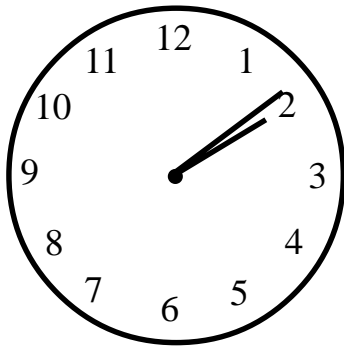

ten after two

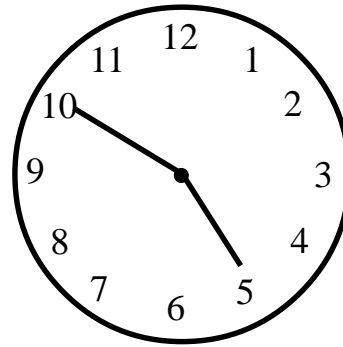

ten to five

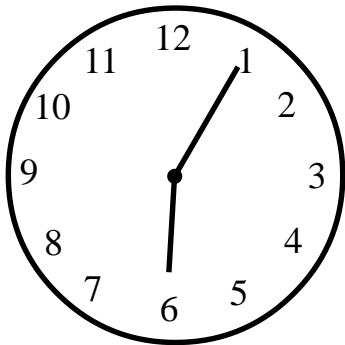

five after six

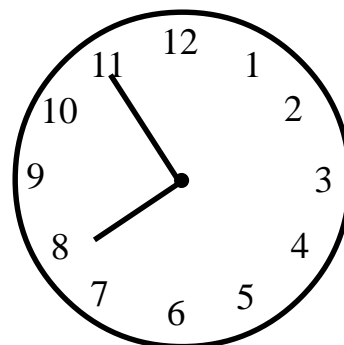

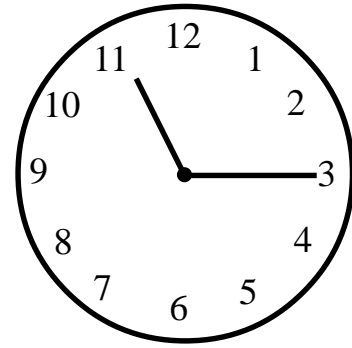

a quarter after eleven

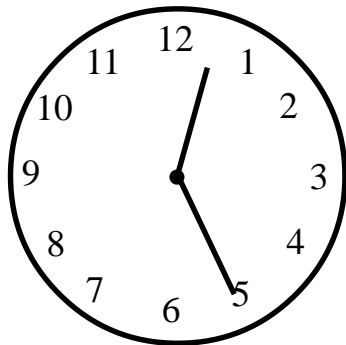

twelve twenty-five

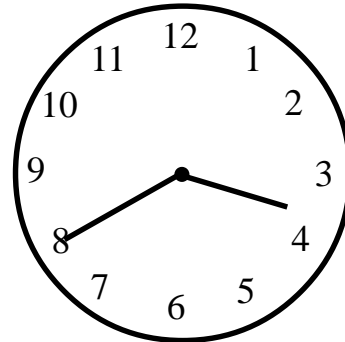
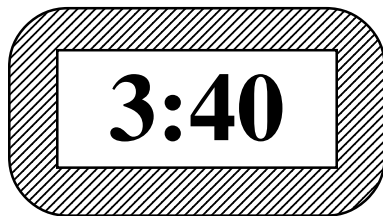

twenty to four



five to eight

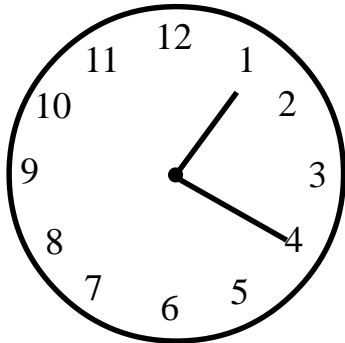

twenty after one

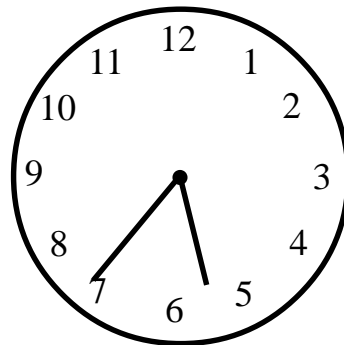

twenty-five to six

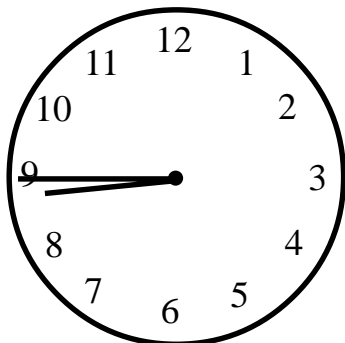
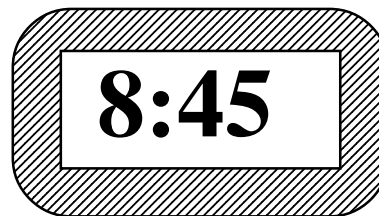

a quarter to nine

Name _____

Date _____

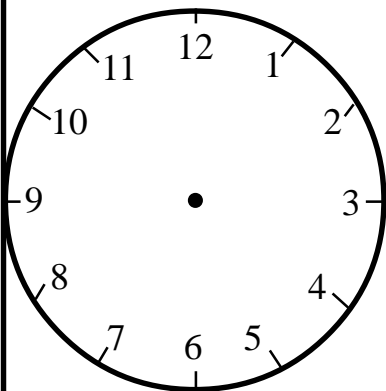
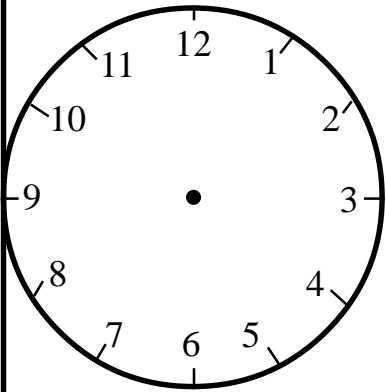
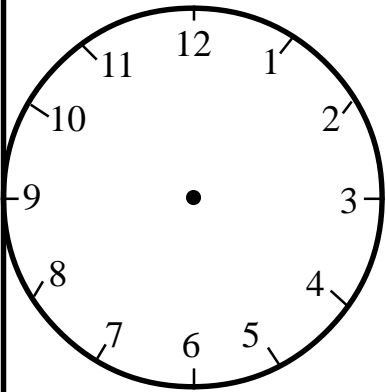
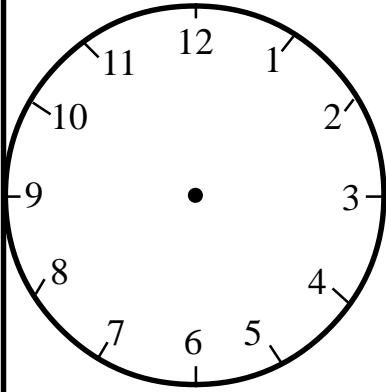

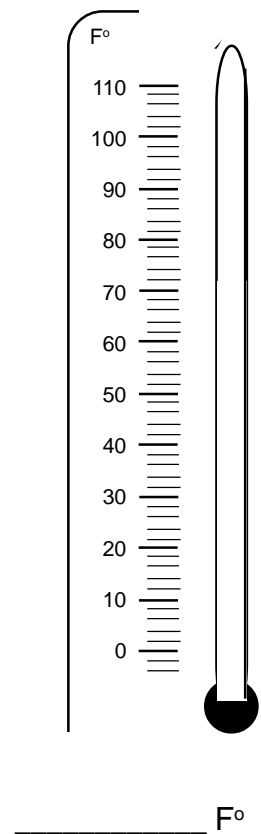
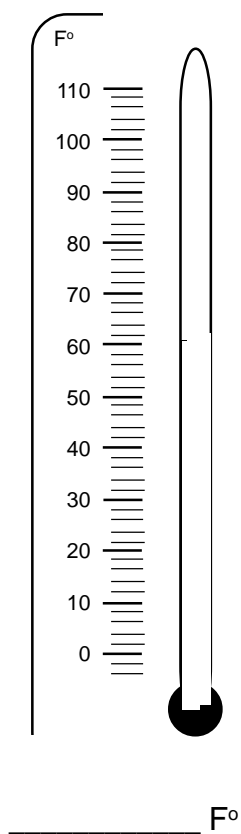
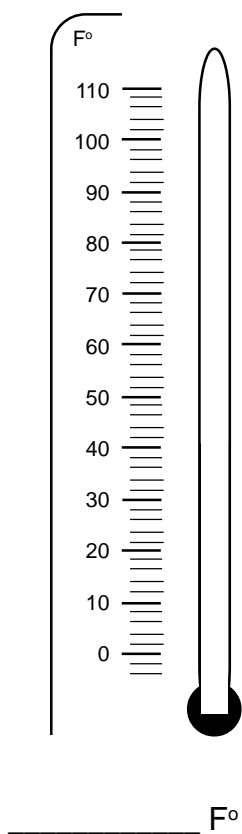
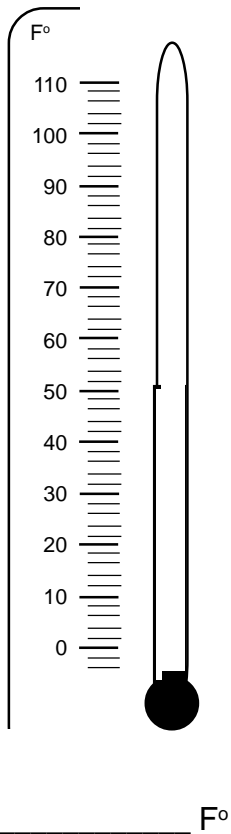
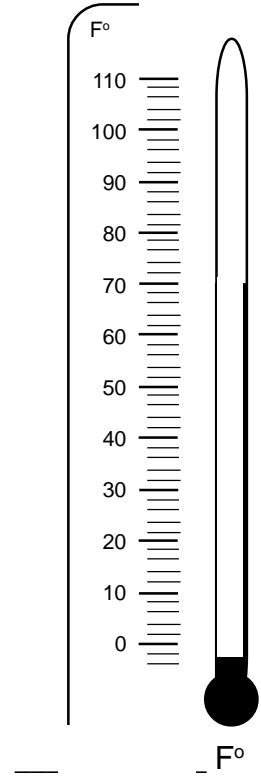
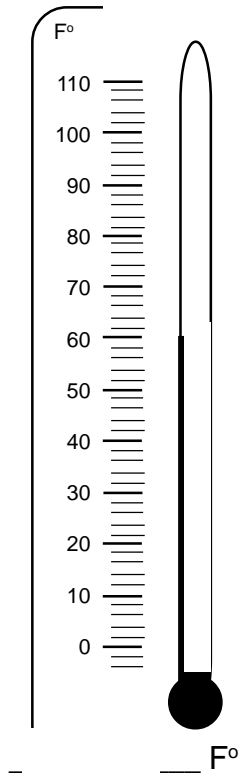
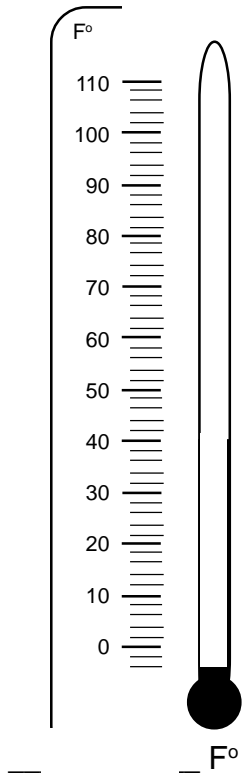
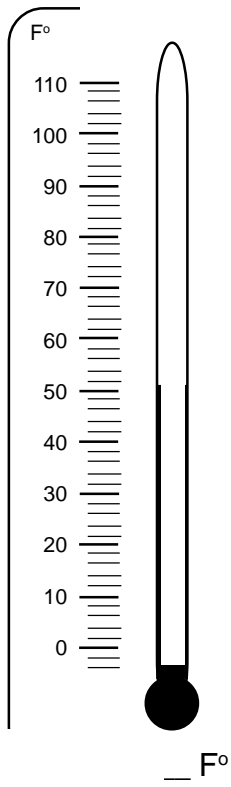

Name _____

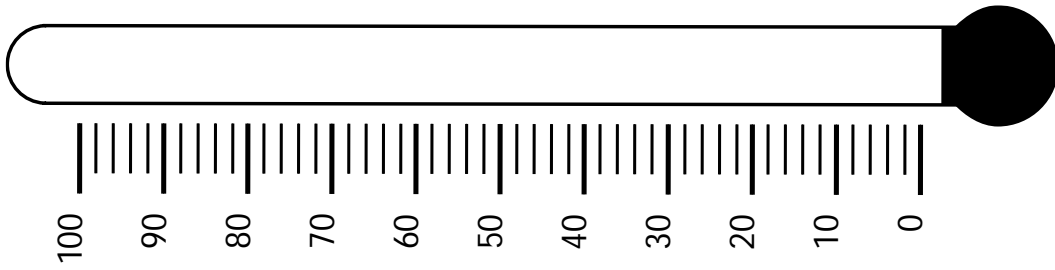

F^0

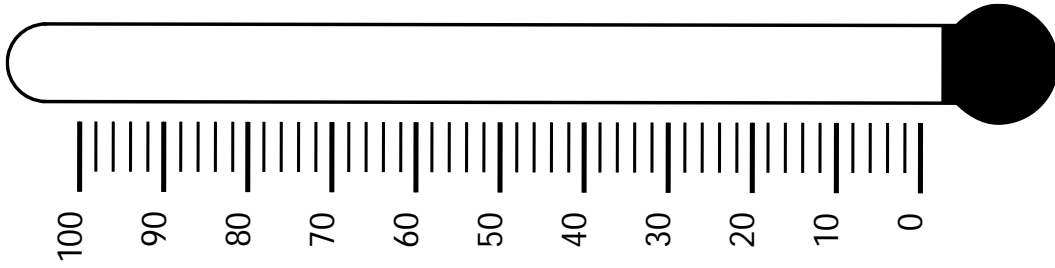

F^0

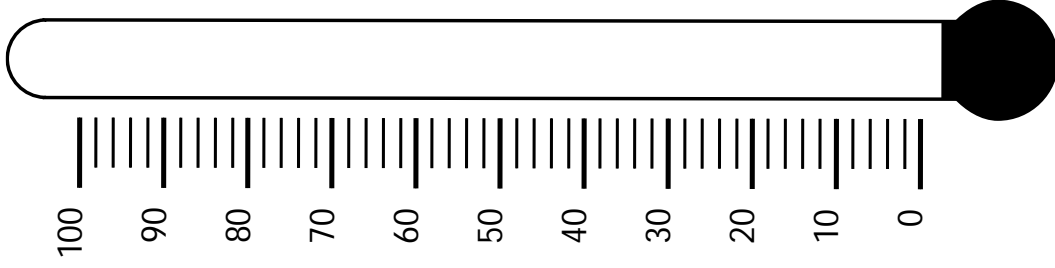

F^0

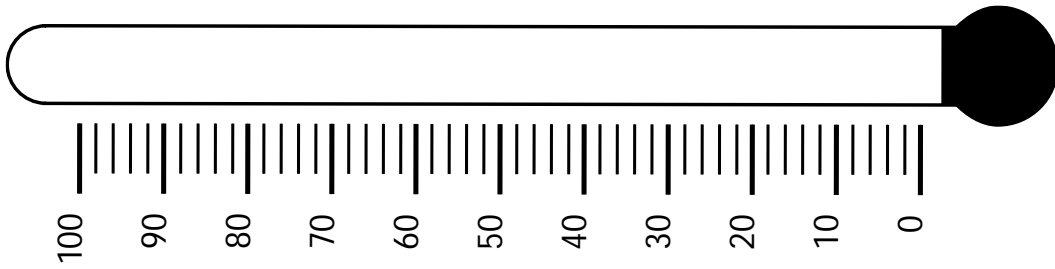

F^0

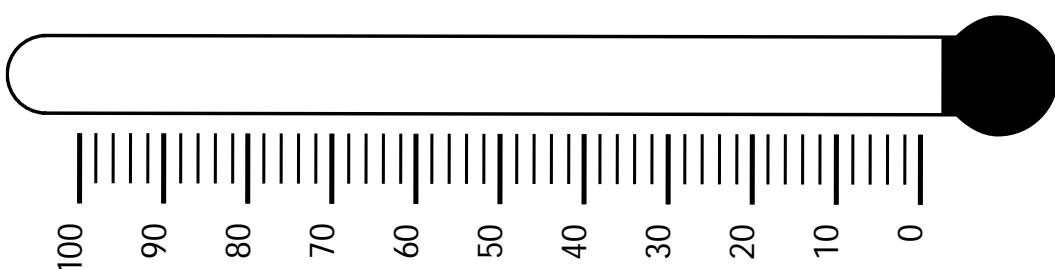

F^0

Name _____

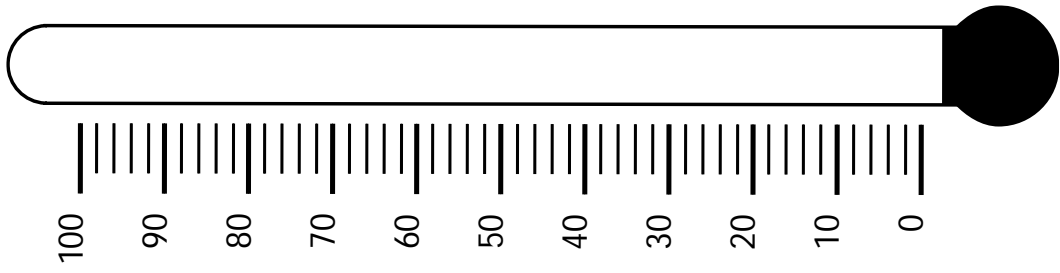

F^0 _____

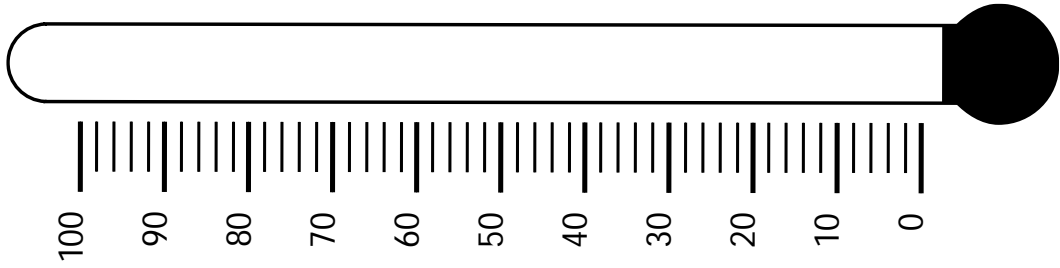

F^0 _____

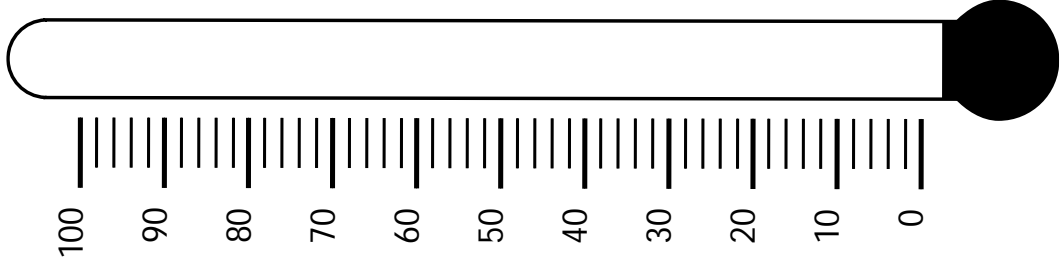

F^0 _____

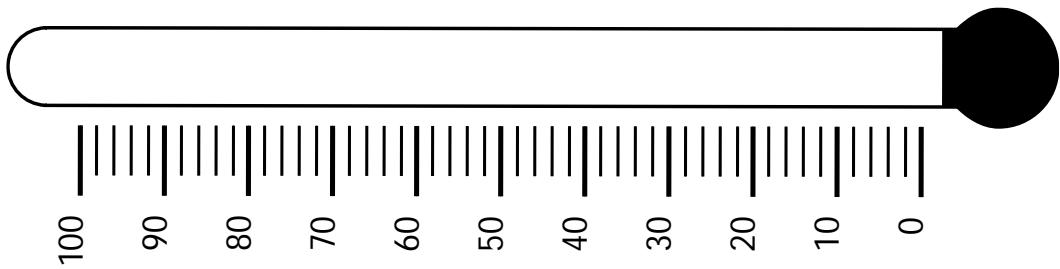

F^0 _____

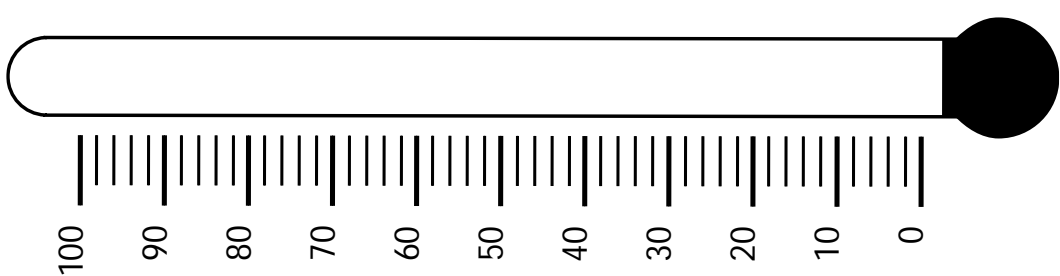

F^0 _____

Recipe _____ Chef _____

Select a recipe. As you measure ingredients, color cups and label them to show how much of each ingredient is used. (Some recipes will not need all of the pictures for the ingredients.) What is the measure of the finished product? On another sheet tell about how you would make this recipe. Be certain to tell whether you think you will like it and whether you would ever make the recipe.

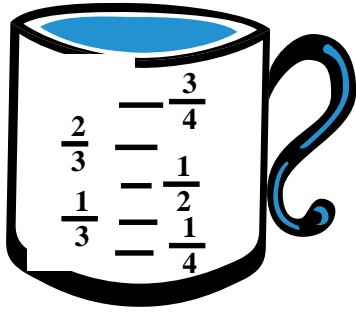

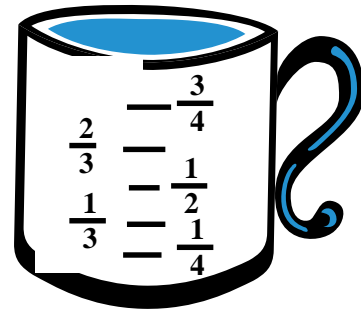

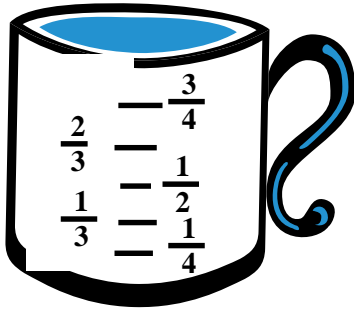

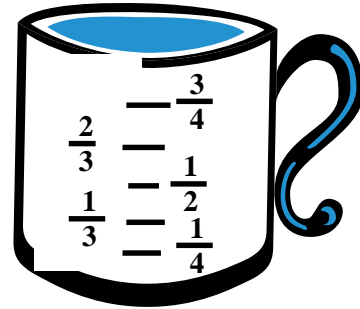

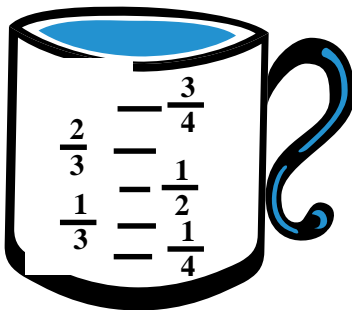

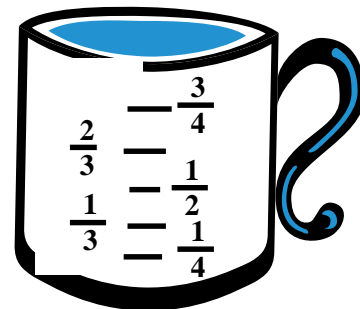

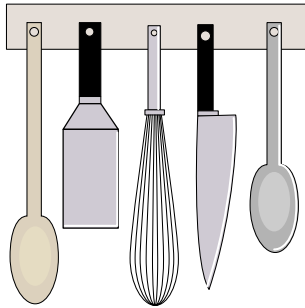

Salsa

- 1 cup diced fresh tomatoes
- $\frac{1}{2}$ cup whole kernel corn
- 2
- $\frac{1}{2}$ cup diced onion
- 2
- 1 Tablespoon chopped jalapeno pepper
- 2 Tablespoons lime juice
- 2 cloves chopped garlic

Combine all ingredients and chill.
Serve with tortilla chips and enjoy!

Fruit Cobbler

- 3 cups fresh or canned fruit
- 2 tablespoons sugar
- 1 $\frac{1}{3}$ cups all-purpose flour
- 3
- $\frac{1}{4}$ cup sugar
- 4
- 2 teaspoons baking powder
- 1 $\frac{1}{2}$ tablespoons margarine or butter
- 2
- $\frac{1}{2}$ cup milk
- 2

- (1) Place 1st 2 ingredients in 1 $\frac{1}{2}$ qt. baking dish and stir.
- (2) Place flour, sugar and baking powder in bowl. Add milk and margarine and stir until mixed.
- (3) Place fruit in baking dish in a warm oven for 10 minutes, or until the sugar begins to melt and fruit softens.
- (4) Drop flour mixture by spoonfuls on hot fruit and bake for 30 minutes at 350° or until fruit bubbles and topping browns.
- (5) Remove from oven and allow to cool slightly. Serve with vanilla ice cream if desired.



Pasta Salad

10 ounces cooked small pasta	$\frac{1}{2}$ cup sliced celery
1 chopped sweet green pepper	2
1 chopped sweet red pepper	$\frac{1}{2}$ cup sliced sweet onion
1 cup diced, seeded cucumber	2
2 shredded medium carrots	6 sliced radishes
1 cup shredded red cabbage	1 small can of tuna, drained

Combine all ingredients and toss with Italian dressing. Chill and serve.

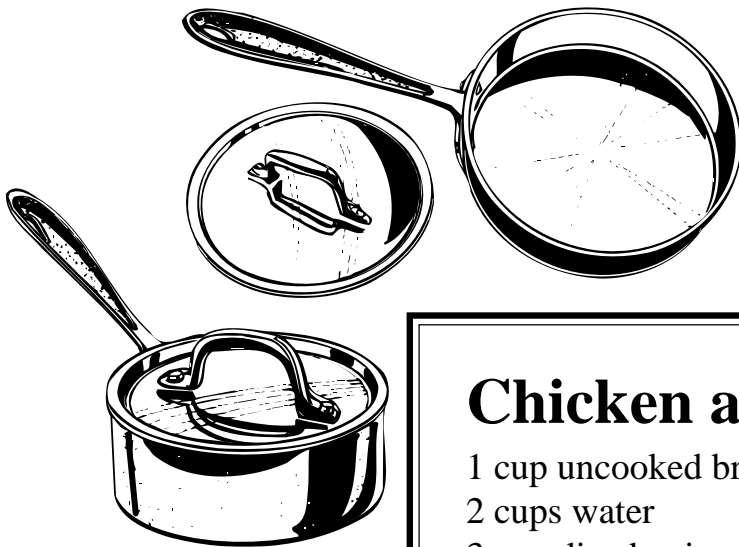

Chicken and Rice

1 cup uncooked brown rice
2 cups water
 $\frac{3}{4}$ cup diced onion
4
1 teaspoon vegetable oil
1 cup chopped celery
1 chopped green pepper
2 cups chopped fresh or canned tomatoes
1 teaspoon salt
 $\frac{1}{2}$ teaspoon each: chili powder, oregano and basil
2
1 cup cooked, diced chicken

(1) Boil water and add rice, onion and oil. cover and cook at low heat for 20-25 minutes.

(2) Add remaining ingredients and simmer until rice is tender.

Name _____

--	--	--	--	--	--	--	--	--	--	--

0 1 2 3 4 5 6 7 8 9

Name _____

--	--	--	--	--	--	--	--	--	--	--

0 1 2 3 4 5 6 7 8 9

Cube Designs

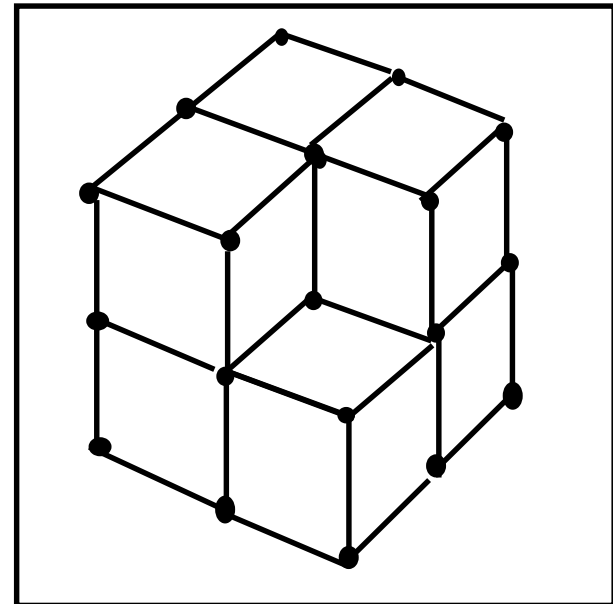
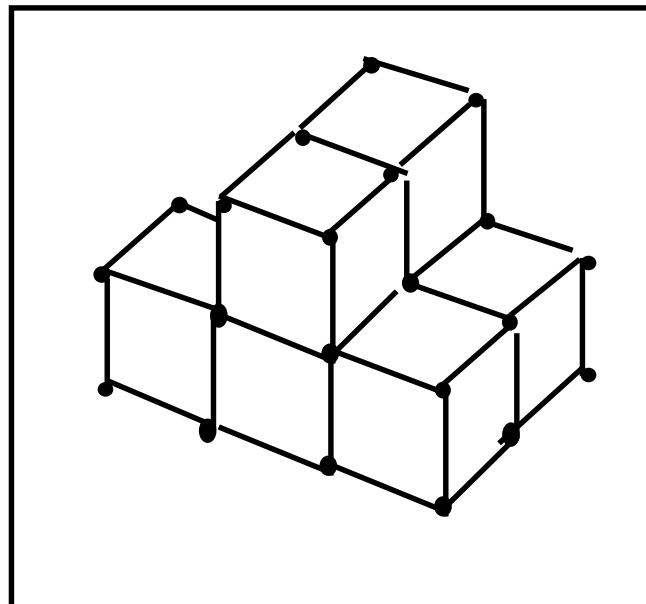
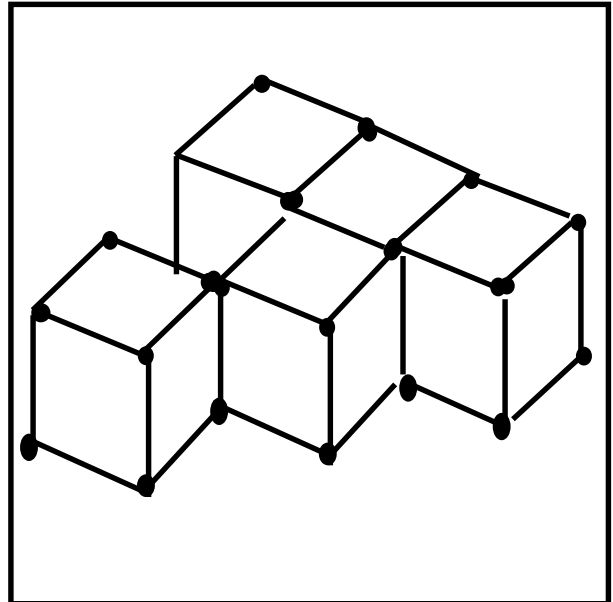
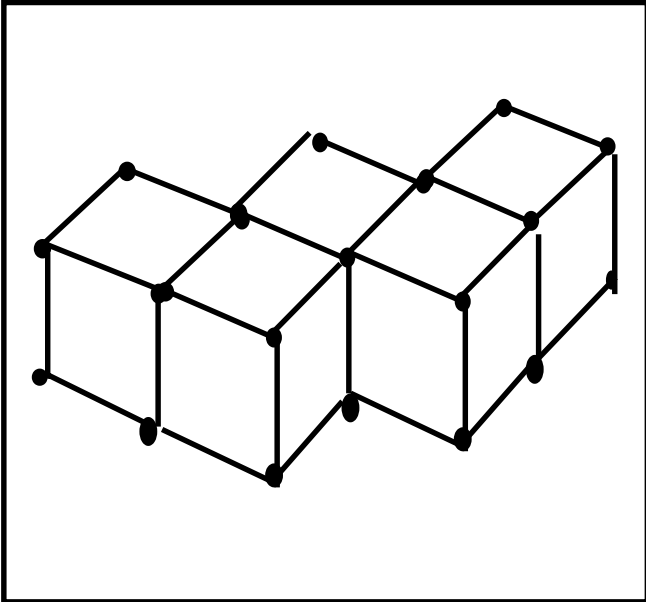
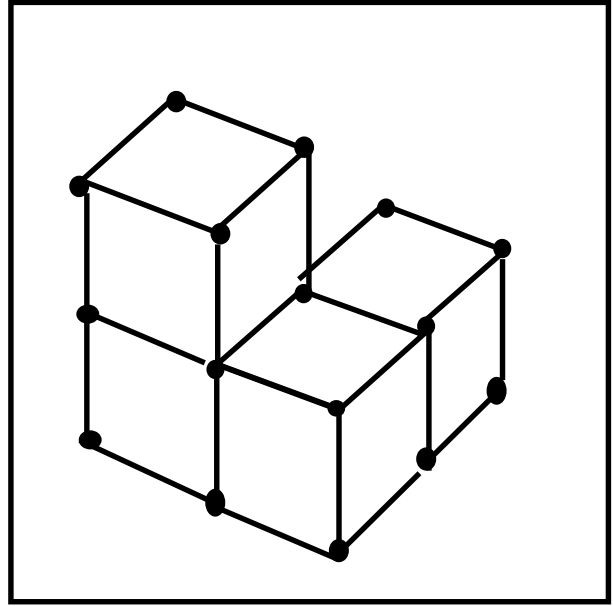
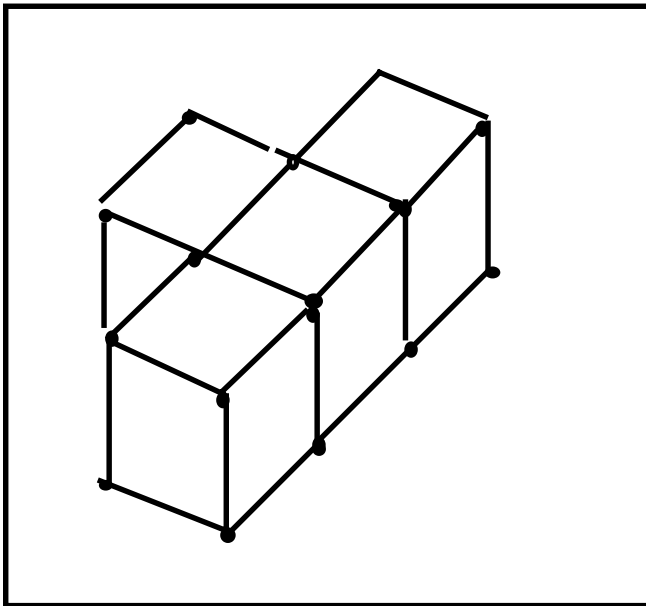

$$1 + 2 = 3$$

$$1 + 3 = 4$$

$$1 + 4 = 5$$

$$1 + 5 = 6$$

$$1 + 6 = 7$$

$$1 + 7 = 8$$

$$1 + 8 = 9$$

$$1 + 9 = 10$$

$$2 + 2 = 4$$

$$3 + 2 = 5$$

$$4 + 2 = 6$$

$$5 + 2 = 7$$

$$6 + 2 = 8$$

$$7 + 2 = 9$$

$$8 + 2 = 10$$

$$3 + 4 = 7$$

$$3 + 5 = 8$$

$$3 + 6 = 9$$

$$2 + 1 = 3$$

$$3 + 1 = 4$$

$$4 + 1 = 5$$

$$5 + 1 = 6$$

$$6 + 1 = 7$$

$$7 + 1 = 8$$

$$8 + 1 = 9$$

$$9 + 1 = 10$$

$$0 + 5 = 5$$

$$2 + 3 = 5$$

$$2 + 4 = 6$$

$$2 + 5 = 7$$

$$2 + 6 = 8$$

$$2 + 7 = 9$$

$$2 + 8 = 10$$

$$4 + 3 = 7$$

$$5 + 3 = 8$$

$$6 + 3 = 9$$

$$7 + 3 = 10$$

$$1 + 0 = 1$$

$$2 + 0 = 2$$

$$3 + 0 = 3$$

$$4 + 0 = 4$$

$$4 + 5 = 9$$

$$5 + 0 = 5$$

$$6 + 0 = 6$$

$$7 + 0 = 7$$

$$3 + 3 = 6$$

$$4 + 4 = 8$$

$$1 + 1 = 2$$

$$8 + 0 = 8$$

$$9 + 0 = 9$$

$$1 + 0 = 1$$

$$0 + 2 = 2$$

$$0 + 7 = 7$$

$$3 + 7 = 10$$

